

TITAN DX ANTENNA

INSTALLATION AND ASSEMBLY INSTRUCTIONS

GAP ANTENNA PRODUCTS, INC.

99 NORTH WILLOW ST. FELLOSVIERE FL 32948 (561) 571-9922

Congratulations on your purchase of the GAP TITAN antenna. You soon will enjoy the ultimate in vertical antenna technology. Your GAP antenna has been designed and manufactured to provide superior performance, and a long trouble free life.

GAP technology produces highly efficient, wide bandwidth performance. As a result, no tuning is required in most amateur installations. This manual is organized to minimize the amount of time necessary to assemble and install your GAP vertical. It is recommended that you follow the instructions and use the figures as a guide.

Before beginning assembly, take a few minutes to read through the site selection chapter and to review the SAFETY notices. Please refer to Figure 1, the TITAN Antenna, as you proceed with the assembly. Locate the parts from Figure 2.

The TITAN has been designed to operate efficiently on eight bands at 1500 watts PEP or less. The TITAN cannot be run continuously i.e. Amtor, RTTY at maximum power on 75/80 meters.

The use of an antenna tuner is not required. Tuners will not improve the performance of the TITAN, however they may permit a solid state transmitter to put out increased power. Operation of an antenna tuner when the VSWR is 2:1 or less is permitted. High power operation outside the specified bands using a tuner can damage the antenna.

CHAPTER 1: SITE CONSIDERATIONS SAFETY - nearby structures, buildings, guying

CHAPTER 2: ANTENNA MOUNTING - Pole, tower, or chimney

CHAPTER 3: MAST ASSEMBLY - Space required, Mast Assembly, Step by Step

CHAPTER 4: TUNER ROD ASSEMBLY - Top, Mid, Lower and Extensions

CHAPTER 5: COUNTERPOISE AND MOUNT ASSEMBLY

CHAPTER 6: INITIAL TEST - First operation ... a place to record VSWR data

CHAPTER 7: TIPS AND TROUBLE SHOOTING

READ THE SAFETY NOTICE ON PAGE 1 BEFORE CONTINUING

SAFETY NOTICE

WARNING! POWER LINES CAN KILL. DO NOT ERECT THIS ANTENNA NEAR ANY OVERHEAD WIRES, UNDER ANY CIRCUMSTANCES. READ AND FOLLOW THESE INSTRUCTIONS CAREFULLY:

1. Do not erect this antenna near any overhead wires. Assume all such wires to be power lines and deadly.
2. Do not transport this antenna from an assembly location to the installation site, if you must travel near or under overhead wires.
3. Request advice from your local power company, if power wires are anywhere near the proposed installation.
4. If the antenna falls, do not try to stop it. Get out of the way.
5. If any part of the antenna should touch overhead wiring, *DO NOT TOUCH IT!* Call the power company immediately for help.
6. In the event of an accident involving power wiring: *DO NOT TOUCH THE VICTIM DIRECTLY.* Send someone for help.
7. Select a site which limits public access to the antenna. During operation the lower tuner rods can be at High RF potential. If any possibility exists that people or pets could touch the antenna, place a small wooden fence around the antenna after installation.
8. Choose a calm, dry day to erect the antenna.
9. Always enlist the aid of at least one person in erecting the antenna.
10. Do not use or stand on a ladder in the process of erecting your GAP Antenna. A ladder is not needed and could be dangerous.
11. Do not connect the antenna coax until the antenna is firmly mounted.

CHAPTER 1: SITE CONSIDERATIONS

1. General Ideally, it is best to locate the TITAN in a clear area, away from wires, metal buildings, fences and trees. As a practical matter, many amateurs must compromise in locating their antennas. This section contains specific guidelines to assist in making those compromises.
2. Site Safety
 1. If you have not read the safety notice, do so now. Stay away from power lines, they are life threatening.
 2. Choose a site that it is not easily accessible to people or pets. **CONTACT WITH THE ANTENNA IS DANGEROUS AND CAN BE FATAL.** The counterpoise rods and the rest of the TITAN may be at high RF potential during operation. If it not possible to site the TITAN to prevent access, then it should be placed high enough such that people cannot reach it or surround it with a fence.
3. Nearby Wires and Antennas
 1. In general, any vertical antenna can exhibit mutual coupling with any other vertical metal structure or wire if placed within a few wavelengths or the structure approaches resonance at the operating frequency.

2. Try to avoid metal objects which may be within 30' of the proposed GAP installation site. These may include wires, towers, downspouts, screened porches, feebleness from other amateur antennas or TV antennas, metal pipes on your property or adjoining properties. Naturally, if these metal objects are short you can get closer than 30'.
 3. Nearby horizontal wires or structures may affect the performance of a vertical antenna, but they are not as likely to, as a vertical structure is.
4. Buildings
1. It is best to locate the antenna as far from the home as possible, to minimize interaction with house wiring, and RFI to consumer electronics.
 2. Metal walled or roofed buildings can affect antenna operation. If you have no choice, your GAP should be located at a corner of the building rather than broadside. In any case, the TITAN should be tested first away from the building. See Section 6.0.
 3. Stucco buildings may have metal mesh in their walls and should be viewed as a metal structures, until proven otherwise.
 4. Mobile homes or RV's are a special case, which involve individual experimentation. Test the antenna on the ground before attempting installation near or on the RV. Mounting above the roof line is preferred.
5. Guying
- The TITAN is designed to withstand substantial winds unguyed. Guys are a form of insurance, however, which we recommend. Four nonconductive guy ropes should be fastened above the center insulator. Use a stainless clamp or optional guy clamp available from GAP. Leave some slack to allow for temperature changes. Guys should be used for roof mounting. Do not rely on a chimney mount or tripod to support the TITAN, even moderate winds can produce enough force to damage the mount or the chimney.

CHAPTER 2: ANTENNA MOUNTING

1. General
The TITAN will accommodate a variety of mounting situations, some of which are described below. The preferred mount is a pole mount. It is simple and avoids the hazards of a roof top installation. Electing to roof mount the antenna is solely your decision and extreme caution should be exercised. If you elect to elevate the antenna, always pre-test the antenna on the ground first. See Section 6.0 Locating a loose connection when the antenna is on top of a 40' mast is not easy!!
2. Pole Mounting
The TITAN is designed to be pole mounted. A mount plate assembly has been provided to attach the TITAN to a pole of your choice. It is recommended that you select a very heavy gauge steel pipe. The outside diameter of which should be 1.25". This pole may be attached to the side of a structure i.e. house or garage for additional support. If you elect to side mount, be certain your pole extends above the roof line to allow clearance for the Counterpoise hoop. Three foot clearance is typical.

If you elect to mount the TITAN on a pole in the yard, the pole should be mounted in an 18" diameter hole 3 feet deep or more and filled with concrete. It is far easier to erect the antenna with your support pole attached, rather than trying to lift the TITAN onto your support pipe. Thus your support pole should be such that it is removable from the concrete. To achieve this, procure a 3' length of 1.25" schedule 40 PVC. Make sure it will sleeve over your support pipe, if it is not large enough slit the pipe lengthwise and slide it over your pipe. Cover the slit with tape and place the PVC covered pipe in the 3' hole and fill with concrete. When the concrete has set remove your support pipe. You can now drop your support pipe into the hole you created by your PVC form.

3. TOWER MOUNTING

The TITAN may be mounted to a tower. Do not clamp directly to the tower Use the Mount Plate Assembly to insulate the TITAN from the tower itself & the support. The TITAN must be placed at the top of the tower and not parallel with it. You may experience reduced bandwidth on a band if you tower mount the TITAN. This is generally a result of the tower exhibiting a resonance for that frequency.

4. TRIPOD/CHIMNEY MOUNT

The TITAN may be mounted in a tripod or to a chimney mount. Use the 'mount plate assembly to insulate the TITAN from the tripod or chimney mount.

CAUTION

The TITAN and mount are in excess of 29' tall. Under no circumstances should a tripod or chimney mount exist without guy ropes. **Guy the antennal.**

CHAPTER 3: ASSEMBLY

1. General

The assembly of the GAP TITAN requires no special tools and a nut driver has been supplied for your convenience. Plastic stand-offs that support the tuner rods are attached to the aluminum mast at their approximate proper positions to simplify assembly. Do not remove these at this time. Before starting assembly, check the various parts in the shipping container against the pictorial parts list in figure B to establish all parts are present. Next review Figure A which depicts an assembled TITAN. As you proceed to assemble your Titan, use this diagram.

NOTE: That in the assembly instructions, when a single hole is identified on a tuner rod it is through drilled. through drilled holes provide you with a backup should you accidentally strip a hole by over tightening.

We found that telling you to insert a screw and washer gets repetitive, therefore. whenever a screw is called for include a washer as well. When attaching jumpers and transitions, the washer should be placed between the ring terminal -and the tube. Not between the screw head and ring terminal. When we refer to the "GAP" we are referencing the center insulator with the yellow band.

2. Space Required

To get started with the assembly, you will need a flat space approximately 30' in length. A driveway or patio surface is ideal. The key to an easy assembly is room to move, a surface which allows you to find the screws you drop and careful attention to the directions. Extra screws have been provided because we know how lawns like to eat screws.

3. Mast Assembly

Standoffs are positioned on the various mast sections at their approximate final positions. Do not loosen the clamps.

1. Locate the Main Section. Place the Main Section on a flat surface. Stretch out the coax that protrudes from each end. NOTE The coax that goes to the top of the antenna has a yellow ring terminal.
2. Locate the Top Section. Place the end without the notch over the coax cable with the yellow terminal.
3. Slide the Top Section into the Main Section. Gently push the Top Section into the Main Section beyond the matching holes, until the yellow terminal and spade connectors are exposed.
4. Plug the CAP unit onto the spade connectors found on the coaxial cable.
Make sure the male spades on the CAP unit align with the female spade terminals on the coax.
5. Pull the Top Section back out and align its four screw holes with the four holes in the Main Mast Section. Insert 4 screws and tighten securely.
6. Place the yellow ring terminal at the top of the antenna through the slot and over the nearby drill hole. Insert a screw and tighten securely.
WARNING: Make sure the CAP unit is pushed down below the screw, so it does not crack the CAP unit when you insert it.
7. Locate the black dust cover and place it over the Top Section.
8. Locate the Mid Section. It has 4 standoffs attached to one end. Slide the end with the 4 standoffs over the coax tail protruding from the Main Section center insulator.
9. Align the holes on the insulator with the holes in the Mid Section. Insert 4 screws and tighten. Leave the standoffs as is for the moment.
10. Locate the Lower Section. It is a double wall section for added strength. It has four long standoffs at one end.
11. Slide the end with the standoffs over the coax tail and partially over the Mid Section. Align the 4 holes, insert 4 screws and tighten securely.

CHAPTER 4: TUNER ROD ASSEMBLY

FIGURE 3

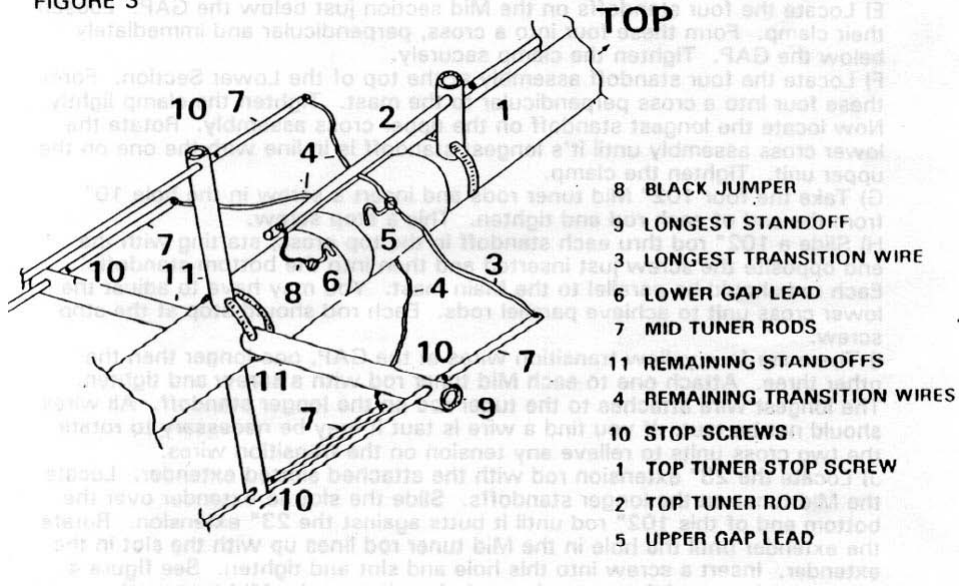

1. GENERAL

There are four 102" Mid tuner rods, two Lower tuner rods 30" and 60" and one 51 " Top tuner rod. Two extender rods complete the tuner rod package. The standoffs have been pre positioned at the factory for your convenience. When orienting these standoffs you should not have to move them along the mast, but simply twist them in their shipped position. If you should slightly shift their relative position along the mast don't despair.. Slight movement is not critical.

1. Locate the two short standoffs on the Main Section. Slide the 51 " Top tuner rod through these standoffs so the screw holes are towards the GAP. Loosen and adjust the standoffs so the tuner rod is parallel to the mast, now tighten the clamps.
2. Locate the drill hole 10" from the end of this tuner rod. Position this hole between the two standoffs and insert a screw and tighten. This is a stop screw Q Slide the tuner rod toward the GAP. Locate a black jumper. Remove the screw holding the lower ' GAP lead, see fig. 3. Place the black jumper under the screw with the GAP' lead, reinsert and tighten.
3. Attach the other end of the jumper to the hole at the end of the Top tuner rod with a screw and tighten.
4. Locate the four standoffs on the Mid section just below the GAP. Loosen their clamp. Form these four into a cross, perpendicular and immediately below the GAP. Tighten the clamp securely.
5. Locate the four standoff assembly at the top of the Lower Section. Form these four into a cross perpendicular to the mast. Tighten the clamp lightly. Now locate the longest standoff on the upper cross assembly. Rotate the lower cross assembly until it's longest standoff is in line with the one on the upper unit. Tighten the clamp.
6. Take the four 102" Mid tuner rods and insert a screw in the hole 10" from the end of each rod and tighten. This a stop screw.

7. Slide a 102" rod through each standoff in the top cross, starting with the end opposite the screw just inserted and then into the bottom standoffs. Each rod should be parallel to the Main mast. You may have to adjust the lower cross unit to achieve parallel rods. Each rod should stop at the stop screw.
8. There are four yellow transition wires at the GAP, one longer than the other three. Attach one to each Mid tuner rod with a screw and tighten. The longest wire attaches to the tuner rod on the longer standoff. All wires should not be taut. If you find a wire is taut it may be necessary to rotate the two cross units to relieve any tension on the transition wires.
9. Locate the 23" extension rod with the attached slotted extender. Locate the Mid tuner on the longer standoffs. Slide the slotted extender over the bottom end of this 102" rod until it butts against the 23" extension. Rotate the extender until the hole in the Mid tuner rod lines up with the slot in the extender. Insert a screw into this hole and slot and tighten. See figure 4.
10. Locate the remaining extender and place it over the Mid tuner rod opposite the tuner rod just installed. Align the slot in the extender with the hole on the tuner rod and secure as in J above so it extends 4.5 inches.
11. Loosen the clamp on the short pair of standoffs on the Lower section. Rotate this pair until they line up with the Mid tuner rods without the extenders.
12. Take the last two short standoffs on the Lower section, loosen each clamp and orient one of these standoffs so it is in line with one from the pair above it. Orient the other so it is in line with the remaining standoff of the pair. Tighten the clamps
13. Slide the shortest Lower tuner rod through the closest spaced standoffs, with the drill hole closest to the GAP. Locate a black jumper and attach one end to the top of the short tuner rod with a screw and tighten.
14. Slide the longer lower tuner rod through the remaining short standoffs, again, so the screw hole is closest to the GAP. Take the remaining black jumper and attach it to the top of this rod with a screw and tighten.
15. Take the other ends of each black jumper and attach it to the Mid Tuner rod directly above with a screw and tighten. These jumpers should be loose. If they are taut you can raise or lower the position of the clamp on the short standoff pair to remove any tension. Proper positioning can be achieved by making sure the bottom of these two Mid tuner rods are in the same plane as the tops of your Lower tuner rods.

FIGURE 4

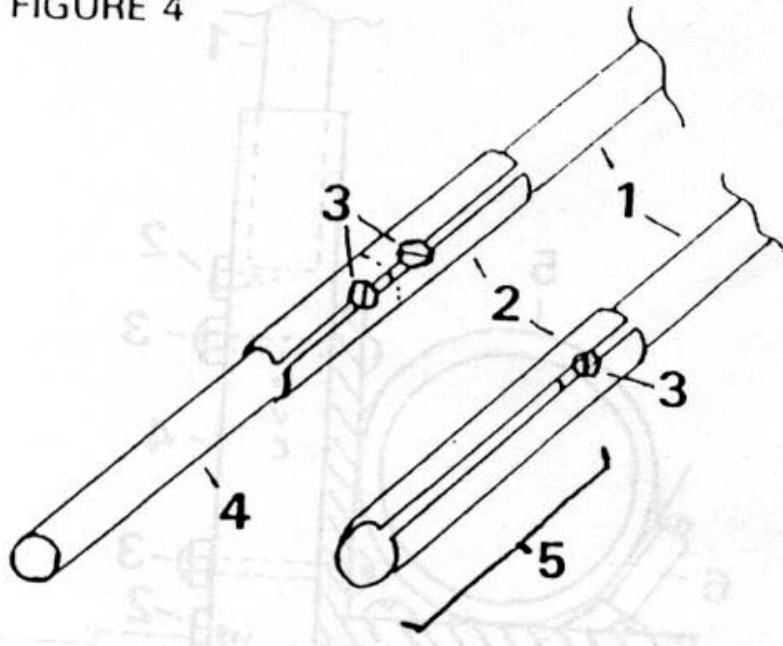

- 5 EXTEND 4.5"
- 1 MID TUNER RODS
- 2 SLOTTED EXTENDERS
- 3 SCREWS
- 4 23" EXTENSION ROD

CHAPTER 5: COUNTERPOISE AND HOOP ASSEMBLY

FIGURE 5

- 1 ALUMINUM COUNTERPOISE TUBE
- 1 COUNTERPOISE RODS
- 1 PVC COUNTERPOISE TUBE
- 3 SCREW
- 7 SCREW - NOT VISABLE
- 6 STAINLESS CLAMP
- 2 STOP SCREW ONLY
- 5 TITAN LOWER SECTION
- 3 1 1/4" SCREW & NYLOCK NUT

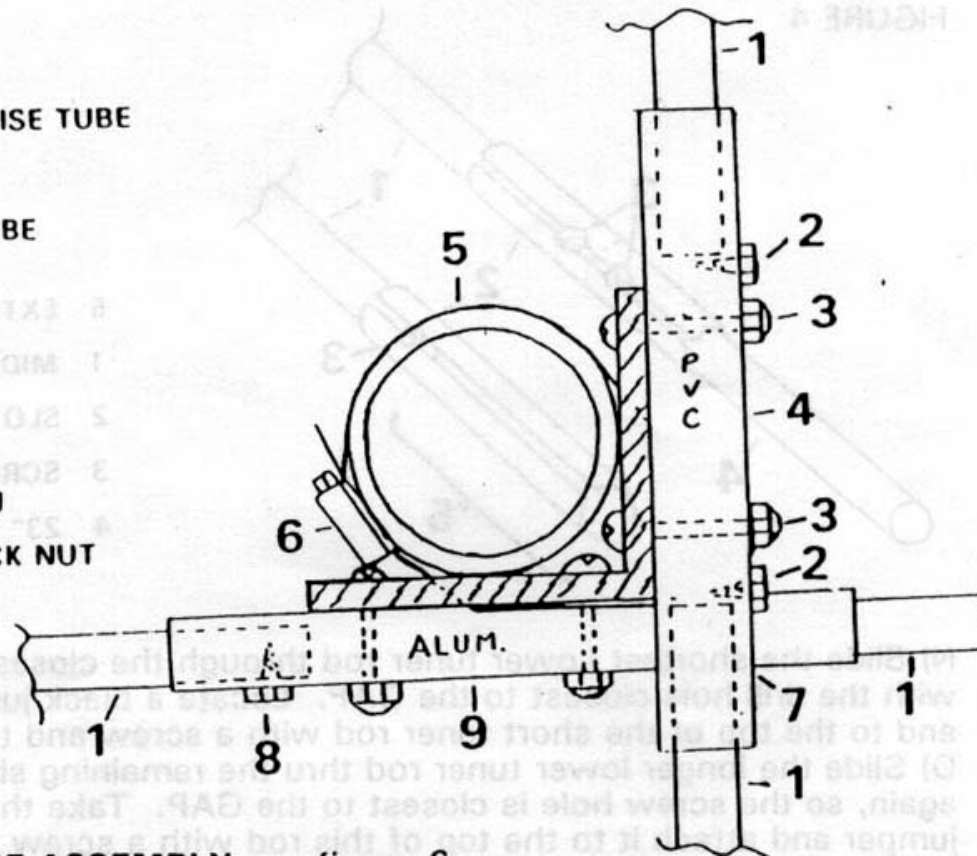

1. GENERAL

The Counterpoise and hoop assembly includes a Counterpoise support bracket, 4-80" rods, Counterpoise Hoop - a 35' length of copper wire with a ring terminal, a 4' length of Dacron with a ring terminal, 3 counterpoise End Caps and a 4' 9" fixed wire extension with 2 ring terminals. The Counterpoise hoop replaces the conventional radials of a ground mounted vertical.

1. Counterpoise Bracket Assembly see figure 5.

1. Locate the Counterpoise bracket. It is partially assembled. Locate the 3/4" x 9" long PVC section with 2 screws attached
2. Push a 1 1/4" screw thru one of the vacant holes in the aluminum bracket. Place one of the drill holes in the PVC tube over this screw.
3. Push a second screw thru the remaining vacant hole in the aluminum bracket and then thru the remaining vacant drill hole in the PVC tube.
4. Attach lock nuts to each screw and tighten both securely

2. COUNTERPOISE ASSEMBLY see figure 6

1. Undo the clamp on the assembled Counterpoise bracket. Place the bracket against the Lower Section in between the two sets of screws at the base.
2. Reconnect the clamp and tighten securely

It is recommended that the Counterpoise Hoop assembly, be deferred until the TITAN has been installed in its final position. RAISING the antenna with the hoop installed is cumbersome and can damage the antenna. The following section is easier to complete after the antenna has been mounted. Check section 6.0 before continuing.

3. COUNTERPOISE HOOP

1. Locate the 80" counterpoise rods. There are drill holes on both ends. Slide each rod into the Counterpoise bracket see figure 5 & 6. Make sure the rod with the yellow end cap slides into one side of the aluminum tube, not the PVC.
2. Align the hole in the 80" rods with the hole in the counterpoise tubes. Insert a screw in both holes and tighten.
3. Locate the 3 Counterpoise End Caps and the 35 foot tinned copper Counterpoise Hoop with 1 ring terminal. The factory has placed a screw in these End Caps.
4. Each End Cap has a thru drilled hole close to one end. Thread the end of the copper wire without the ring terminal thru these holes in the End Caps.
5. Locate the wire extension with the two ring terminals.
6. Take the ring terminal from the Counterpoise Hoop wire and one terminal from the wire extension. Place both terminals over the drill hole at the end of the 80" counterpoise rod that has the yellow end cap and is attached to the aluminum tube on the Counterpoise bracket. see figure 6. Insert a screw attaching these terminals to the Counterpoise rod.
7. Circle the ends of the Counterpoise rods with the Counterpoise Hoop placing an End Cap on each Counterpoise rod as you circle.
8. Find the Dacron cord with the ring terminal. Feed the end of the Counterpoise wire thru the ring terminal on the Dacron cord about 18", fold it back on itself and secure with the split bolt.
9. Thread the Dacron cord thru the vacant ring terminal of the wire extension. Pull the cord until the hoop has no slack in it but, do not over tension the hoop. Tie a temporary knot in the Dacron cord to the ring terminal on the wire extension.

FIGURE 6

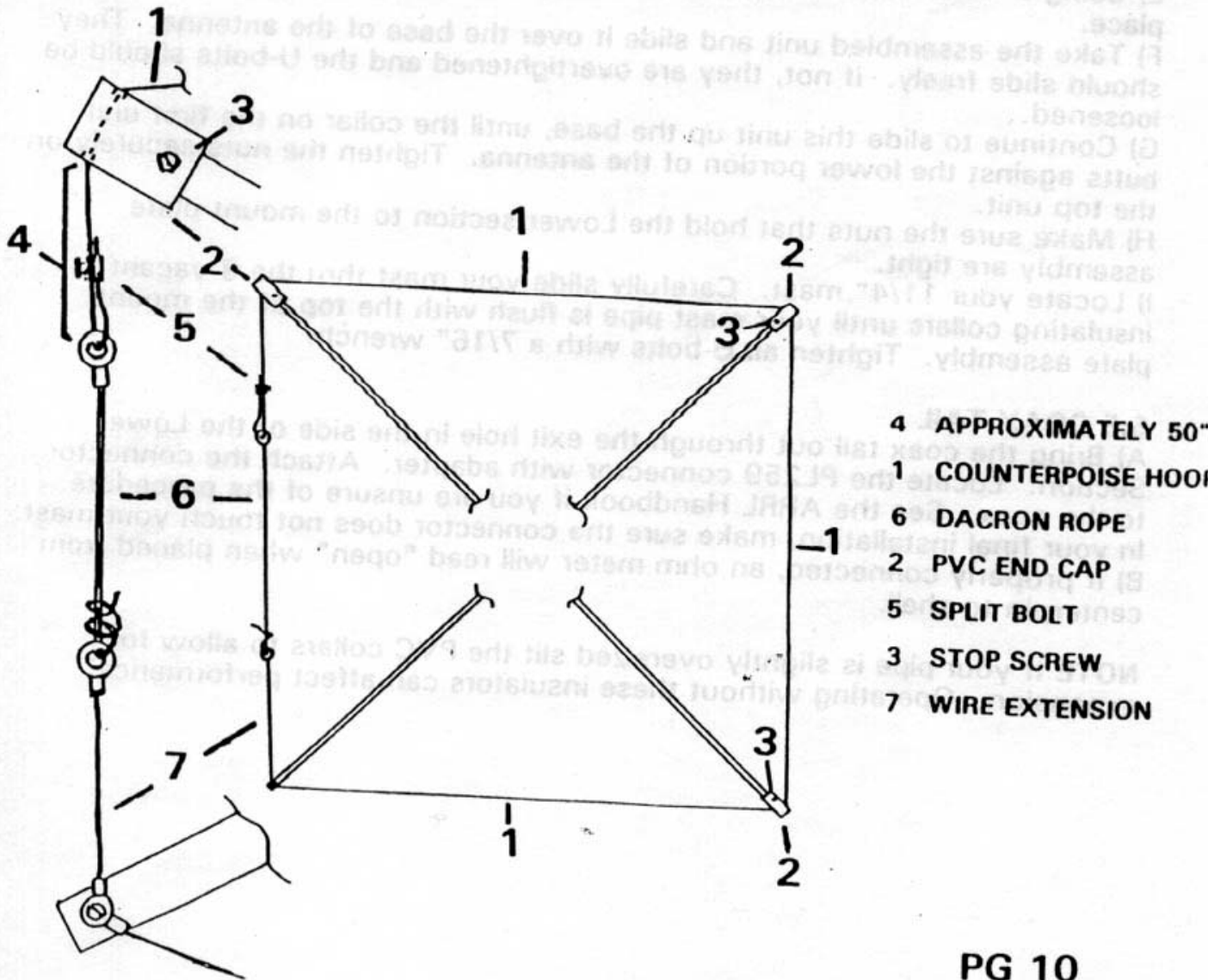

PG 10

IMPORTANT The length of the Counterpoise Hoop controls the center frequency on 40m. The longer the Counterpoise wire is, the shorter the Dacron rope is and the lower the resonant frequency will be. Likewise the shorter the length of the Counterpoise Hoop the higher the resonant frequency will be and the longer the Dacron rope will be. Adjust the Counterpoise Hoop so that it ends about 50" from the last End Cap and check the frequency with your VSWR meter on 40m. Adjust the length to suit your preference on 40m.

1. 5.4 POLE MOUNT ASSEMBLY-REFER TO FIGURE 7
 1. Locate the 3"x1 2" aluminum plate, the six U-bolts and twelve nuts.
 2. Insert the U-bolts into the plate as shown in figure 7.
 3. Finger tighten the nuts on the ends of all the U-bolts.
 4. Locate the six collar insulators. Place each under a U-bolt.

5. Using a 7/16" wrench tighten the U-bolts until the collars are just held in place.
 6. Take the assembled unit and slide it over the base of the antenna. They should slide freely. If not, they are overtightened and the U-bolts should be loosened.
 7. Continue to slide this unit up the base, until the collar on the first unit butts, against the lower portion of the antenna. Tighten the nuts securely on the top unit.
 8. Make sure the nuts that hold the Lower section to the mount plate assembly are tight.
 9. Locate your 1 1/4" mast. Carefully slide your mast thru the 3 vacant insulating collars until your mast pipe is flush with the top of the mount plate assembly. Tighten all U-bolts with a 7/16" wrench
2. COAX TAIL
1. A) Bring the coax tail out through the exit hole in the side of the Lower Section. Locate the PL259 connector with adapter. Attach the connector to the coax. See the ARRL Handbook if you are unsure of the procedure. In your final installation, make sure the connector does not touch your mast.
 2. If properly connected, an ohm meter will read "open" when placed from centerpin to shell.

NOTE If your pipe is slightly oversized slit the PVC collars to allow for expansion. Operating without these insulators can affect performance.

6.0 PRETEST PROCEDURE

It is always best to test the TITAN at ground level before elevating it. Pretesting is not difficult and may save time and effort in-the total process. This is particularly true if the antenna is to be significantly elevated.

FIGURE 7

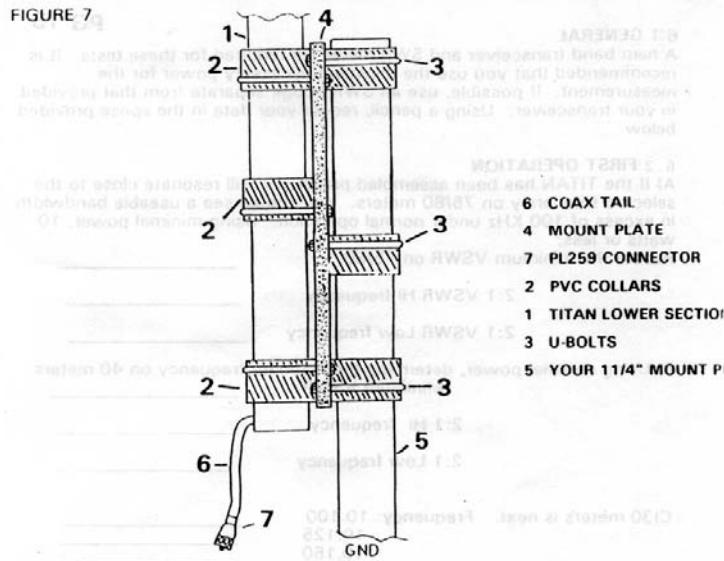

1. Locate an open space.
2. Obtain an 1 1/4" pipe 5' long.
3. Attach this pipe to the TITAN see section 5.4.
4. Obtain 3 lengths of rope 25-30' long.
5. Attach ropes just above the GAP.
6. Insert a screw driver or small diameter tube in the ground.
7. With help raise the antenna until it is vertical.
8. Place your 5* pipe over the screwdriver or tube, this will keep the base in place.
9. Secure the temporary guy ropes
10. Complete the hoop assembly see section 5.3. For this test it is not necessary to put screws into the Counterpoise rods.

2. GENERAL

A ham band transceiver and SWR meter are required for these tests. It is recommended that you use the minimum necessary power for the measurement. If possible, use an SWR bridge separate from that provided in your transceiver. Using a pencil, record your data in the space provided below.

3. FIRST OPERATION

1. If the TITAN has been assembled properly it will resonate close to the selected frequency on 75~80 meters. You should see a useable bandwidth in excess of 100 KHz under normal operation. Using minimal power, 10 watts or less; Record the minimum VSWR on 75/80. _____
 2:1 VSWR Hi frequency _____
 2:1 VSWR Low frequency _____
2. Using minimal power, determine the resonate frequency on 40 meters.
 Minimum VSWR _____
 2:1 Hi frequency _____
 2:1 Low frequency _____

3. 30 meters is next. Frequency: 10.100 _____
 10.125 _____
 10.150 _____
4. 20 meters 14.00 _____
 14.175 _____
 14.350 _____
5. 17 meters 18.068 _____
 18.118 _____
 8.168 _____
6. 15 meters 21.00 _____
 21.225 _____
 21.450 _____
7. 12 meters 24.890 _____
 24.990 _____
8. 10 meters 28.00 _____
 28.50 _____
 29.00 _____

CHAPTER 7 TIPS AND TROUBLE SHOOTING

1. The TITAN DX-VIII has been designed to operate on the 8 bands specified. Operation outside the -- specified bands may damage the antenna. Use of an antenna tuner is not required nor recommended. Tuners will not improve the performance of the antenna, although they may permit a solid state transmitter to put out more power. Operation of the antenna using a tuner on any frequency where the VSWR exceeds 2:1 may damage the antenna. Use when VSWR is less than 2:1 is acceptable.
2. MALFUNCTION
 1. If the antenna fails to resonate on the 75/80 meter band the CAP unit plugged on at the top of the antenna may not be making proper contact or was inadvertently shorted when the screw was inserted.
 2. If all your standing waves are high, double check the PL259 connector at the base of the antenna and make sure it is open from center pin to shield.
 3. If only a couple of bands are high eliminate the following possibilities;
 1. Bad coaxial feedline. If the coax has been in use for some time, it may be contaminated. Place a 50 ohm dummy load at the far end of your feedline, in place of the antenna. Any indication of varying VSWR or a standing wave greater than 1 :1 suggest defective coax.
 2. Mutual coupling with nearby vertical metal objects may detune the TITAN. Check to see if any of the items suggested in section 1.2 & 1.3 apply.
 3. Transceivers with built in SWR bridges may not correctly indicate when their power reduction circuits take over. Retest with a separate VSWR meter.

4. The transceiver or transmitter may be emitting a spurious signal in addition to the desired signal. Retest using the lowest possible power level. If possible try another rig.

If you are unable to solve the problem, contact the factory for assistance. Please have section 6.2 filled in and handy when you call. We do not charge for assistance and our phone number is (561) 571-9922.

Back to [WA8PHD](#)

[The Institute for Idiomatic Pursuits](#)

<http://www.ifip.com/>

May 28, 20001

[thought provoking
quotes](#)

[WA8PHD](#)

[Weather](#)

["FLUENT" APHASIA](#)

[Stoke and Diabetes](#)

[Aphasia, Stoke and
Diabetes](#)

[Academic and Ph.D.
Studies](#)

[Flying](#)

[Criminal Justice
Work](#)

[Inca Art](#)

[pho-tog-ra-phy](#)

[Machu Picchu](#)

[Hiram Bingham](#)

[Personal and more](#)

**The Institute for Idiomatic
Pursuit's
[Internet store](#)**

**[The Institute for Idiomatic
Pursuits](#)
(Home)**

[Site Map](#)